

# ARC SYSTEM

Multifunctional and versatile surveillance and communications platform.



PRODUCT BROCHURE



We Think Exceptional.

part of the **wj** group



[www.wjsunstone.com](http://www.wjsunstone.com)



[info@wjsunstone.com](mailto:info@wjsunstone.com)

# ARC SYSTEM

**THE ARC IS A ROBUST, RAPIDLY DEPLOYABLE SOLAR POWERED CCTV TOWER WHICH PROVIDES RELIABLE, COST-EFFECTIVE SECURITY FOR ALL TYPES OF SITES. WHAT DOES IT DO?**

Provides 24/7 HD CCTV surveillance with intrusion detection alerts that can be streamed via a mobile network to any location or device, powered by solar.

## STANDARD FEATURES

- Multiple options to integrate static cameras and Pan Tilt Zoom (PTZ) and options for thermal or bullet cameras
- Rapid deployment and no working from heights
- Integrated smart analytics including intrusion detection and perimeter security
- PA horn for instant live or pre-recorded audio deterrents
- Out of hours alarm monitoring with pre-agreed escalation process
- Access to live and recorded video footage on mobile devices through an encrypted cloud-based viewing application
- Up to 30 days of recorded video footage
- 4m telescopic CCTV mast
- Integration into any Video Management System
- Remote system health monitoring and automatic alerts
- Designed and Manufactured in the UK

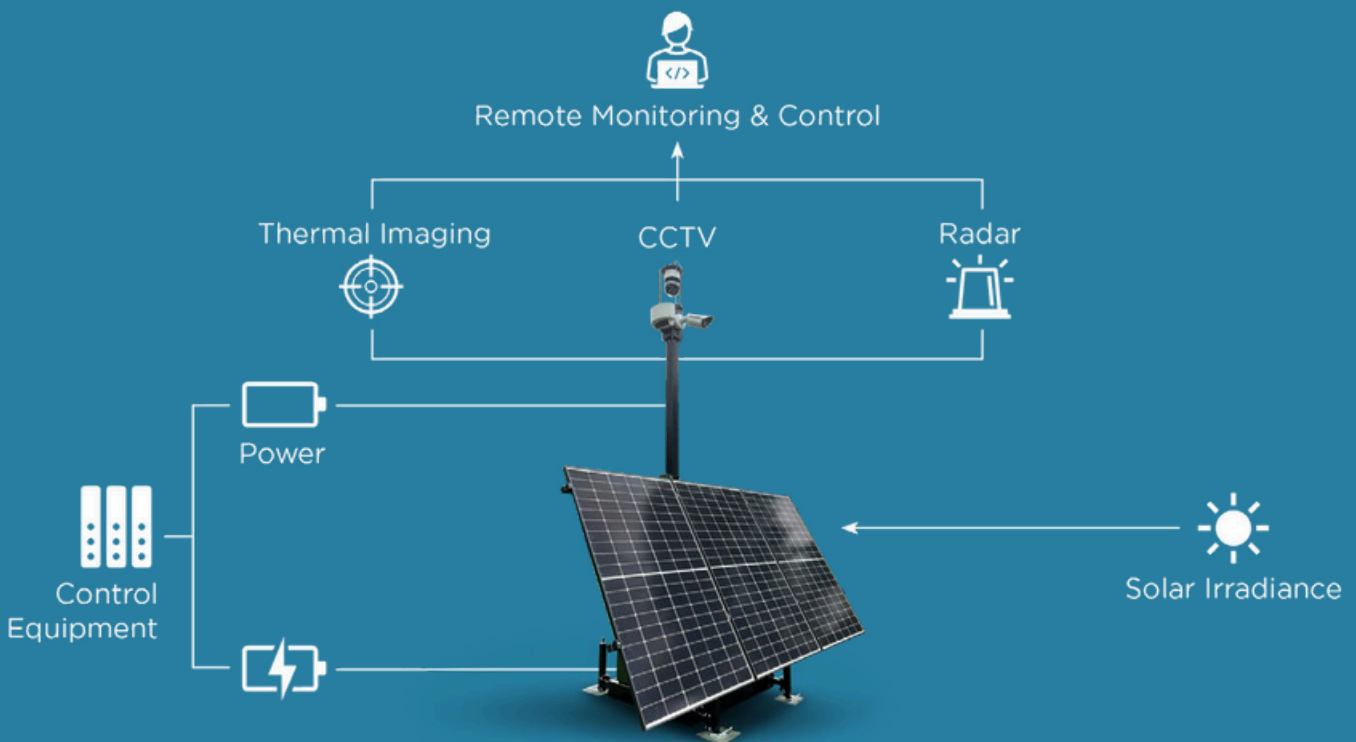



# BENEFITS

## BENEFITS OF ARC

- Rapidly and easily deployable, cameras live and streaming in minutes
- Versatile deployment, moved around site as it develops, and requirements change
- Secure, lockable IP66 rated cabinet, tamper alerts and encrypted data
- Ruggedised, vandal resistant, built to last
- Integrate analytics including hard hat and hi-vis detection, fire detection
- Proven in deployments in Highways, Rail, Construction, and Oil and Gas
- Can deliver siteWi-Fi (subject to site survey)
- Optional methanol fuel cell back up to provide autonomous power delivery all year round
- Branded, add your logos or colours
- Green, reduce CO<sub>2</sub> emissions by up to 500kg per year to diesel generators

**"WE HAVE BEEN  
EXTREMELY PLEASED  
WITH THE SURVEILLANCE  
UNITS PROVIDED BY  
SUNSTONE SYSTEMS"  
CONSTRUCTION MANAGER  
AT BALFOUR BEATTY**





# ARC SYSTEM OPTIONS



## CCTV Surveillance Cameras

We can integrate a range of different camera types, specifications and manufacturers. This includes Bullet, PTZ and 180/360 Degree Cameras. The feed can be relayed from the ARC and to the Cloud to be monitored.



## Automatic Number Plate Recognition

Our ANPR cameras deliver detection and capture of numberplates, providing remote vehicle eligibility to enter controlled locations or to monitor traffic. Data can be streamed in real time to the monitoring centre.



## Radar Detection

Our range of range radar detectors are integrated into the ARC and are designed to work with CCTV cameras. Any detections would be confirmed visually by using the cameras and alerts relayed to the monitoring centre.



## TASCAR

Our systems are used for the enforcement of mandatory speed limits using distance over time technology and have been shown to increase speed compliance, reduce congestion and improve road user and road worker safety.



## Thermal Imaging

Deploying thermal imaging cameras are most effective in complicated locations and over long distances. Detecting the thermal signature of an intruder, an alert is relayed via the cellular network and to the monitoring centre.





# SECURITY OPTIONS

## Smart Analytics

Our analytics transform video, audio, and other data into valuable insights you can act on instantly. We use learning software and triggers that let you respond appropriately to security and safety breaches as they occur. Our analytics options include:



Fence Guard detects and triggers an event when objects cross a predefined virtual line in the camera view.



Loitering Guard tracks moving objects and triggers an event if they've been in an area for too long.



Motion Guard detects and triggers an event when objects move within a predefined area in the camera view.



Video Motion detects and triggers an event when objects move within a predefined area in the camera view.



Perimeter Defender delivers physical access controls at the perimeter of your site.



Object Analytics detects and classifies humans and vehicles tailored to your surveillance needs.

Example Deployment: ARC System (Security Platform) deployed into each corner of the construction site. Each ARC has integrated CCTV Cameras and Radar constantly sweeping the area and using analytics can detect intruders. They can issue an audio warning, inform a local security team or alert monitoring centre.



# DATASHEET

## UNIT DIMENSIONS

- Transport: H 2250mm W 1200mm D 1300mm
- Deployed: H 4500mm W 2200mm D1500mm

## OPERATING PARAMETERS

- -20°C to +50°C
- Power: 720w solar panel array
- Voltage: 24V
- Battery System: 400Ah
- Weight: 750kg

## CABINET

- Material: Painted steel, corrosion resistant
- Features:
  - Integrated Solar Array
  - Lifting Eye Points
  - Dual doors with dust/water seals
  - Concealed door hinges
  - IP Rating: IP66

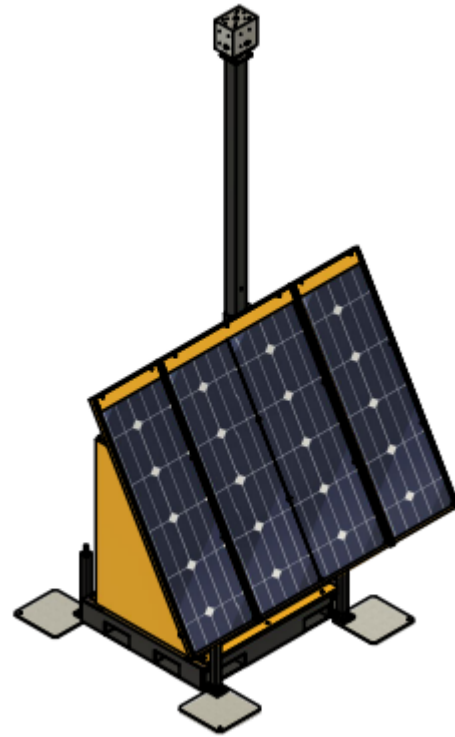
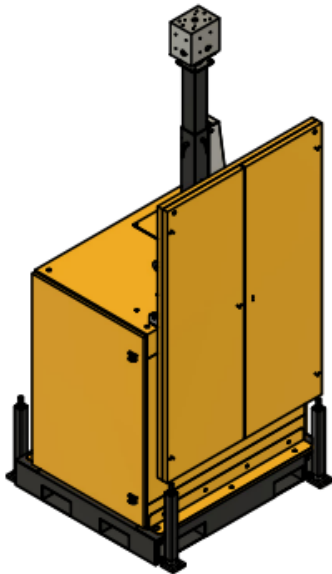

## TRANSPORT BASE

- Painted steel, corrosion resistant
- Integrated forklift slots, pump truck slots
- Adjustable stabilising legs

## STANDARD MAST

Features:

- Anti-wind loading design
- Painted steel, corrosion resistant
- Deployed Height: 4m
- Servicing Height: 2m

## OTHER

Certifications:

- EAC Certification
- CE Marking

British Standards:

- Eurocode 3 – Design of steel structures, BS EN 1993-3-1:2006
- Eurocode 1- Actions on structures, BS EN 1991-1-4:2005
- Eurocode 3 – Design of steel structures, BS EN 1993-3-2:2006



### Security

- CCTV Surveillance
- Smart Analytics
- Perimeter Detection
- Remote Monitoring



### Telecoms

- Temporary Event WIFI
- Mobile Hotspot
- Point to Point Networks



### Oil & Gas

- Site Security
- Wellhead Telecoms
- Gas Detection



### Rail

- Trackside Monitoring
- Set down Yard Security
- Passenger Surveillance & Monitoring



### Construction

- Site Security
- Health & Safety
- 24/7 Hotspot & WIFI



### Highways

- Traffic Monitoring
- Average Speed Detection (TASCAR)
- Air Quality Monitoring





Unit 1, Altira Business Park, The Boulevard, Herne Bay,  
Kent, CT6 6GZ  
United Kingdom

+44 (0) 3301 066666



FS 651086



SHORTLISTED



british engineering excellence awards



HIGHLY COMMENDED



WINNER



WINNER



ENGINEERING & MANUFACTURING AWARDS



WINNER



FINALIST



COMMENDED Innovation



We Think Exceptional.

part of the **wj**group



[www.wjsunstone.com](http://www.wjsunstone.com)



[info@wjsunstone.com](mailto:info@wjsunstone.com)