

# ARC GENERATOR SYSTEM

ARC-GEN delivers reliable solar and methanol power for off-grid applications.



---

PRODUCT BROCHURE



We Think Exceptional.

part of the **wj** group



[www.wjsunstone.com](http://www.wjsunstone.com)



[info@wjsunstone.com](mailto:info@wjsunstone.com)

# ARC GENERATOR SYSTEM

ARC-GEN is a sustainable and versatile power platform that combines solar and methanol energy. It delivers hybrid power solutions to remote and disconnected locations, supporting various sensors, IoT devices, and telecommunications equipment.

Engineered to excel in challenging environments, the ARC-GEN operates intelligently, ensuring continuous functionality by autonomously recharging itself day and night. This system provides a dependable and uninterrupted power source precisely where it's required.

- Environmental Friendliness > ARC-GEN is environmentally friendly, optimising solar yield, emitting extremely low CO2 emissions and is constructed from recyclable components.
- Continuous Energy Supply > It provides 24/7 energy through a combination of solar and methanol power, ensuring reliable operation year-round.
- Reliability > The system has been tested and proven to operate reliably in extreme weather conditions and temperatures, making it suitable for various challenging environments.
- Energy Independence > It reduces the reliance on hardwired power or data connections, making it ideal for remote and off-grid locations.
- Automation > The system automatically charges through solar power during the day and uses the methanol generator to recharge the batteries at night, ensuring continuous operation.
- Rapid Deployment > ARC-GEN can be rapidly deployed, especially on highways, to reduce road closures and increase safety.



# FEATURES

The ARC-GEN System offers the capability to deliver both solar and methanol power, catering to a broad spectrum of stationary and mobile applications. This includes vital sectors Highways, Rail, Oil and Gas and Defence. When deployed in off-grid locations, ARC-GEN not only provides essential power but also ensures connectivity and integrates smart technologies precisely where they are needed.

## STANDARD FEATURES

- **Solar and Methanol Power** > The ARC-GEN combines solar and methanol generator technology to generate up to 200kWh of power per month. This dual power source ensures continuous energy supply, making it suitable for various applications.
- **Durable Construction** > The system is built to withstand harsh environments, with steel and powder-coated components. It also features integrated forklift slots and lifting points for easy deployment in remote and challenging locations.
- **Security Measures** > The ARC-GEN is designed with anti-theft and anti-vandalism features, including built-in GPS, concealed hinges, a ruggedised and lockable cabinet with an IP66 rating. This ensures the system remains secure and operational in remote areas.
- **Connectivity** > The system is equipped with integrated 4G and 5G cellular connectivity, allowing for real-time data transfer and proactive onboard maintenance all year round.
- **Advanced Control System** > The ARC-GEN includes an advanced control system that enables remote monitoring of system performance. This capability enhances reliability and simplifies maintenance, especially in remote locations.
- **Methanol Fuel Management** > The integrated methanol generator and fuel management system when combined with solar, extend the generators and battery lifespan, and reduce CO2 emissions.

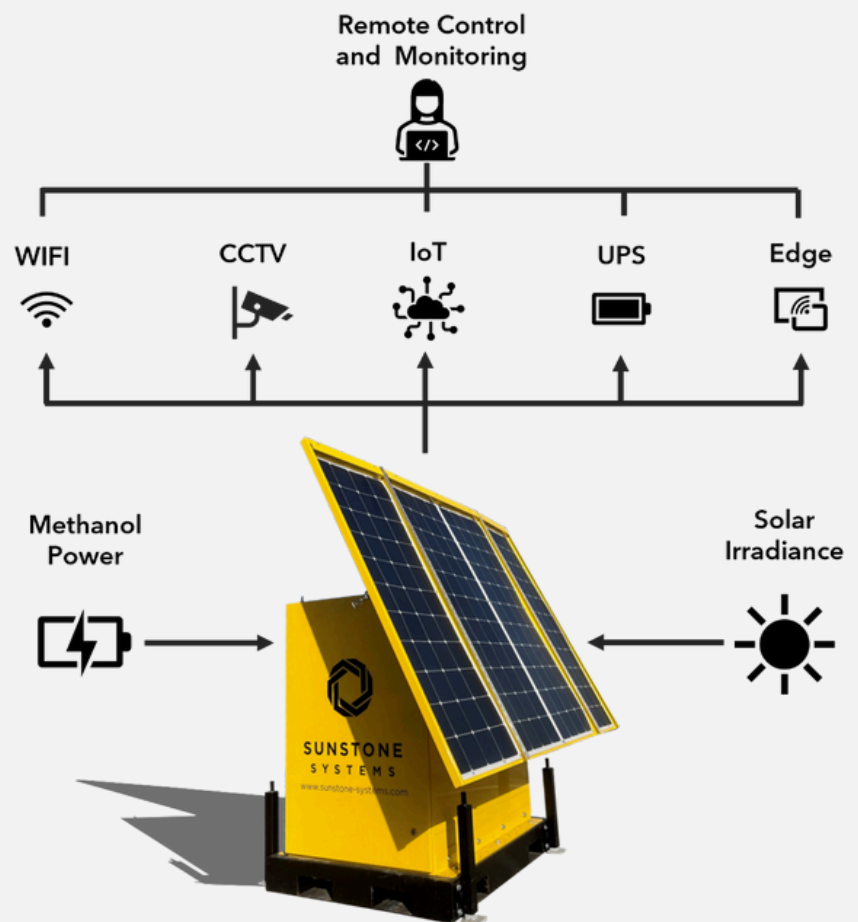



# APPLICATIONS





ARC-GEN applications encompass a wide range of industries, whether deployed at remote surveillance locations, off-grid telecommunications sites, or in need of backup power for IoT devices, the ARC-GEN steps up to the challenge. It's specifically engineered to operate effectively in demanding environments, ensuring continuous functionality, reliable power, and connectivity where it's needed most. With its adaptability and reliability, the ARC-GEN is an asset for a multitude of applications, helping bridge the gap in power and connectivity in remote and disconnected areas.

- 

**RAIL** > ARC-GEN is an advanced hybrid power platform, leveraging solar and methanol to provide telecommunications and surveillance at level crossings, depots and train stations. This system can provide reliable and clean energy in complex and disconnected trackside locations anywhere.
- 

**SECURITY** > ARC-GEN delivers reliable power in all conditions for a range of surveillance and security sensors. Streaming footage, analytics and alerts in real time to your monitoring centre all year round.
- 

**TELECOMMUNICATIONS** > ARC-GEN provides power for connectivity, including wireless point to point, mesh, cellular and satellite networks disconnected locations. This hybrid power platform can deliver reliable and clean energy for your telecommunications devices, delivering connections where you need it.
- 

**CONSTRUCTION** > Developed for rugged environments, ARC-GEN provides day one telecommunications for office buildings and advanced perimeter detection to protect your assets and vehicles.
- 

**HIGHWAYS** > Designed for remote and off-grid locations, ARC-GEN powers specialist highways IoT devices, radars and surveillance cameras. In addition, due to the high-power capability, it delivers power for TASCAR, Stopped Vehicle Detection, Barriers and Welfare Kiosks.



# DATASHEET

## ARC-GEN SPECIFICATION

### UNIT DIMENSIONS

- Length (For transport): 1100mm
- Width (For transport): 1200mm
- Height (For transport): 1500mm
- Length (Deployed): 1600mm
- Width (Deployed): 2400mm
- Height (Deployed): 2000mm

### BATTERY SYSTEM VOLTAGE

- 400Ah at 24V

### BATTERY CAPACITY

- 6kWh @80% DoD

### OUTPUT VOLTAGE

- 230VAC to Loads

### EXTERNAL POWER INTERFACE

- 230VAC

### OPERATING TEMPERATURE

- -20 to +50 Degrees

### WEIGHT

- 800kg (with fuel) 680kg (without fuel)

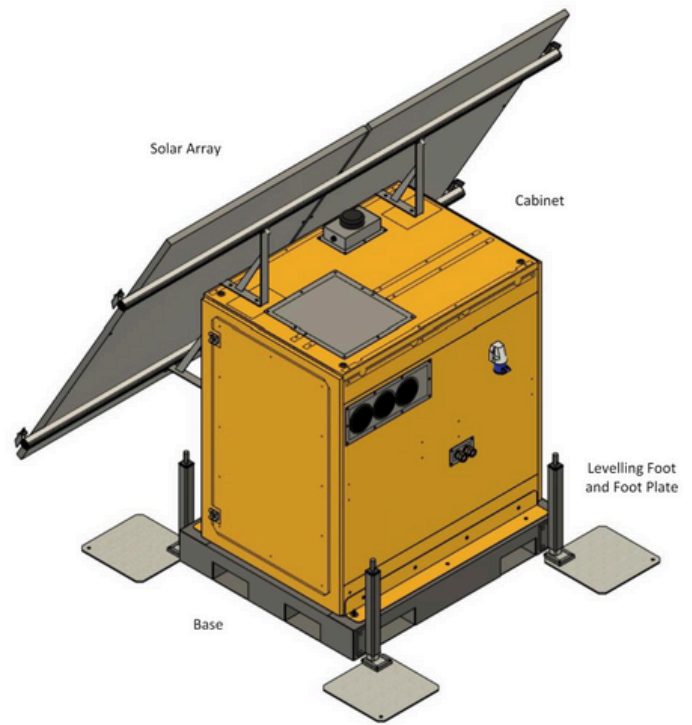

### ARC-GEN EXTREME CABINET

- Powder coated steel, corrosion resistant, Dual doors with dust/water seals, Concealed door hinges and foldable or fixed solar array

### SOLAR ARRAY

- 720w – 1kWh

### IP RATING

- IP66 Rated

### ARC-GEN SYSTEM SOFTWARE

- Remote system health status and power performance monitoring

### TRANSPORT BASE

- Painted steel, corrosion resistant
- Integrated forklift, pump truck slots and lifting points
- Adjustable stabilising legs and footplates

### ARC-GEN FUEL

- 120L (Generator consumes 0.9L / kWh)
- 132kWh energy capacity
- 110kg fuel weight

### MAXIMUM POWER OUTPUT

- 250w

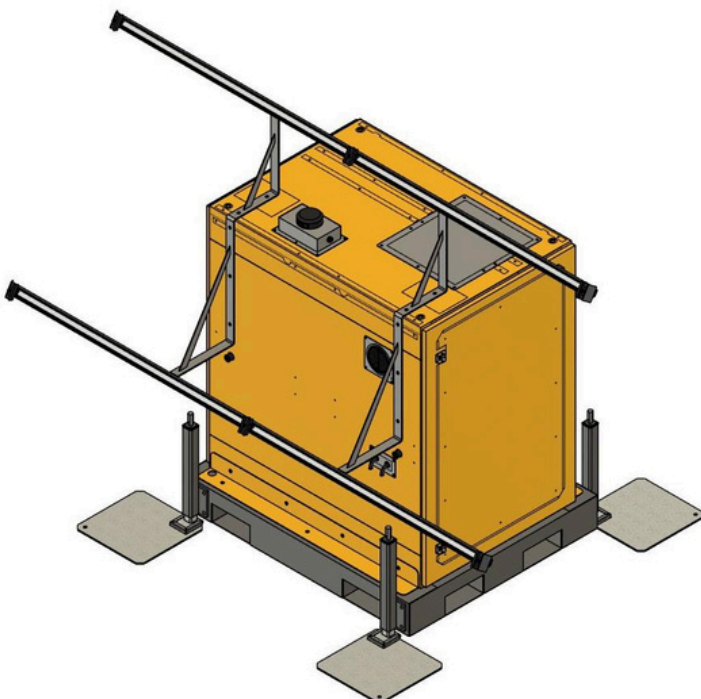



Unit 1, Altira Business Park, The Boulevard, Herne Bay,  
Kent, CT6 6GZ  
United Kingdom

+44 (0)1227 369 470



FS 651086



We Think Exceptional.

part of the **wj** group



[www.wjsunstone.com](http://www.wjsunstone.com)



[info@wjsunstone.com](mailto:info@wjsunstone.com)